

UNIT : mm

尺寸公差 Tolerance										
項目 Tolerance	1/4~3/8	8A - 10A 1/2" - 3/4"	15A-65A 1" - 3"	80A-200A 4" - 6"	200A-300A					
Outside Diameter	±0.1mm			±0.1%						
Wall Thickness	±10%									
Straight End Lengh	±Do Not Spectfy,-0.4mm									
Radins	±0.8mm			±1.6mm			±3.2mm			
R+L(A)	±0.8mm			±1.6mm			±3.2mm			
品質保證 Quality Assurance										
各向量測試 Measurment Type			316LBA			316LEP				
表面缺陷數(EA) Suface Defect(EA)			---			≤20				
氧化厚增數 (A) Oxide Thinkncss(A)			---			≥20				
鎳鐵比&氧化鎳對氧化鐵比 Cr/Fe Ratio			---			≥1.5				
微粒子 Particle Density			1PC@0.3mm			1PC@0.1mm				
油份測定(mg/ft²)Oil Denstiy(mg/ft²)			≤0.01			≤0.01				
材質成分 Material										
規格 Grade		化學成分 Chemical Compositions%								
JIS	ASTM	C	Si	Mn	P	S	Ni	S	Mo	
SUS304	(AISI 304)	≤0.08	≤1.00 (≤0.75)	≤2.00	≤0.040	≤0.030	8.00-11.00	18.00-20.00	---	
SUS304L	(AISI 304L)	≤0.030 (≤0.035)	≤1.00 (≤0.75)	≤2.00	≤0.040	≤0.030	9.00-13.00 (8.00-13.00)	18.00-20.00	---	
SUS316	(AISI 316)	≤0.08	≤1.00 (≤0.75)	≤2.00	≤0.040	≤0.030	10.00-14.00	16.00-18.00	2.00-3.00	
SUS316L	(SISI 316L)	≤0.030 (≤0.035)	≤1.00 (≤0.75)	≤2.00	≤0.040	≤0.030	12.00-16.00 (10.00-16.00)	16.00-18.00	2.00-3.00	
管內研磨處理 Inside Surface Process Grade										
研磨方式 Process		等級稱呼 Abbreviation		尺寸範圍 Size Range		粗糙度 Roughness				
						RA		RY max		
精抽+光輝處理 Cold Pilger Mill+BA		BA		≤100A		0.4um		3.0um		
機械拋光(環狀) Mechanical Polishrment(Chrculation)		MP		65A≤OD≤100A		0.4um		3.0um		
				125A≤OD≤300A		0.5um		4.0um		
				≤800A		0.5um		5.0um		
機械拋光(直線) MP(longitu dinal)		MP		65A≤OD≤100A		0.4um		3.0um		
機械拋光+電解研磨 MP+Electopolishment		MP+EP		65A≤OD≤100A		0.3um		3.0um		
				125≤OD≤300A		0.3um		3.0um		
BA+電解研磨 BA+EP		EP		≤50A		0.2um		0.5um		
包裝等級 Package Grade										
項目		AP	MP	MP+EP	BA	EP				
最終洗淨 Final Cleaning		無油處理 Degreasing	無油處理 Degreasing	無油處理 Degreasing (C/R1000)	精密洗淨 (C/R1000)	精密洗淨 (C/R1000)				
內表面處理 Inside Surface Procs		-----	機械拋光 MP	機械+電解 MP+EP	精抽+機械 Cold Pilger Mill	電解研磨 BA+EP				
內表面粗細度 Inside Surface Roughness		≤100A=(4")	Ry≤2.5um	Ry≤3.0um	Ry≤2.0um	Ry≤3.0um	Ry≤0.5um			
		125A~350A	-----	Ry≤4.0um	Ry≤2.5um	-----	-----			
		≤800A	-----	Ry≤5.0um	Ry≤3.0um	-----	-----			

UNIT : mm

PIPE SIZE (A-SIZE)						
Normal Pipe	Outside Diameter at End	Wall Thickness at End		Straight End Length	Thinning Length	
		T			J	
	OD	5S	10S	L	5S	10S
8A	13.8	1.20	1.65	29	4	7
10A	17.3	1.20	1.65	36	4	7
15A	21.7	1.65	2.10	36	5	7
20A	27.2	1.65	2.10	36	5	7
25A	34.	1.65	2.80	36	5	7
32A	42.7	1.65	2.80	46	5	7
20A	48.6	1.65	2.80	46	5	7
50A	60.5	1.65	2.80	46	5	7
65A	76.3	2.10	3.00	51	6	1
80A	89.1	2.10	3.00	51	6	1
100A	114.3	2.10	3.00	51	6	1
125A	139.38	2.80	3.40	56	7	1
150A	165.2	2.80	3.40	56	7	1
200A	216.3	2.80	4.00	56	7	1
250A	267.4	3.40	4.00			
300A	318.5	4.00	4.50			

UNIT : mm

PIPE SIZE (INCH-SIZE)				
Normal Tube	Outside Diameter at End	Wall Thickness at End	Straight End Length	Thinning Length
	OD	T (T1 . T2)	L	J
1/8"	3.18	0.7	29	7
1/4"	6.35	1.0(0.89)	29	7
3/8"	9.53	1.0(0.89)	29	7
1/2"	12.70	1.0,1.24(1.65)	29	7
5/8"	15.88	1.0(1.24)	36	7
3/4"	19.05	1.24,1.65	36	7
1"	25.40	1.24,1.65	36	7
1 1/4"	31.80	1.65	36	7
1 1/2"	38.10	1.65	46	7
2"	50.80	1.65	46	7
2 1/2"	63.50	1.65	51	7
3"	76.20	1.65	51	11
4"	101.60	2.11	51	11
5"	127.00	2.77,3.05	56	11
6"	152.40	2.77,3.05	56	11

UNIT : mm

公稱尺寸 Normal Pipe Size [RC,RE] (大徑端) (Large end)	彎頭 90°Elbow 標準[90R] Standard Elbow		彎頭 45°Elbow 標準[45R] Standard Elbow		管帽 Cap [Cap]	大小頭 Rcducer		
	同心大小頭[RC] Conccntric Rcducer		偏心大小頭[RE] Eccentric Rcducer					
OD(OD1)	R	A	R	A	E	E		E
INCH-SIZE								
1/4"	20	49	20	38	12.7	[1/8"]		70
3/8"	23	52	23	39	12.7	[1/4"]		RC70,RE80
1/2"	25	54	25	40	25.4	3/8" [1/4"]		RC75,RE85
5/8"	28	64	28	48	25.4	[1/2" ,3/8" ,1/4" ,8A]		90
3/4"	30	66	30	49	25.4	[5/8"],1/2" [3/8" ,1/4" ,10A](8A)		100
1"	33	69	33	50	38.1	3/4" ,[5/8"],1/2" [3/8" ,1/4" ,15A](8A~10A)		105
A-SIZE								
8A	25.4	55	25.4	40	12.7	[1/2",3/8",1/4"]		RC80,RE85
10A	25.4	62	25.4	47	19.1	[8A,1/2",3/8",1/4"]		90
15A	38.1	75	38.1	52	25.4	[10A,8A,3/4",1/2",3/8",1/4"]		100
20A	38.1	75	38.1	52	25.4	15A,[10A,8A,1",3/4",1/2",3/8",1/4"]		105
25A	38.1	75	38.1	52	38.1	20A,15A,[10A,8A,1-1/4",1",3/4",1/2",3/8",1/4"]		120
32A	47.6	94	47.6	66	38.1	25A,20A,15A,[1-1/2",1-1/4"](10A~8A,1"-1/4")		125
40A	57.2	104	57.2	70	56	32A,25A,20A,15A[1-1/2"](10A~8A,1-1/4"~1/4")		130
50A	76.2	123	76.2	78	60	40A,32A,25A,20A[2"](15A~8A,1-1/2"~1/4")		140
65A	95.3	147	95.3	91	62	50A,40A,32A,25A,[3",2-1/2"](20A~8A,2"~1/4")		165
80A	114.3	166	114.3	99	65	65A,50A,40A,32A,[3"](25A~8A,2-1/2"~1/4")		170
100A	152.4	204	152.4	115	72	80A,65A,50A,40A,[4"](32A~8A,3"~1/4")		180
125A	127.0	185	190.5	145	84	100A,80A,65A,50A,[5"](40A~8A,4"~1/4")		250
150A	152.4	210	228.6	155	92	125A,100A,80A,65A,[6"](50A~8A,5"~1/4")		260
200A	204.8	375	304.8	195	103	150A,125A,100A(80A~8A,6"~1/4")		280

圖形Drawing

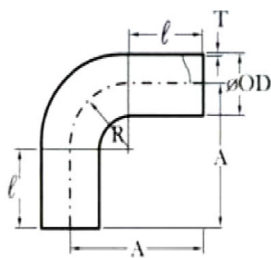

彎頭 90° Elbow

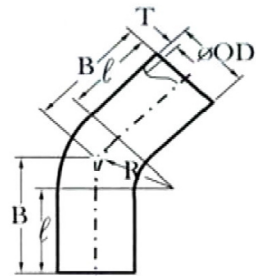

彎頭 45° Elbow

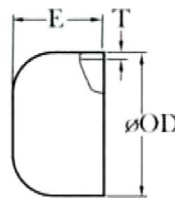

管帽 Cap

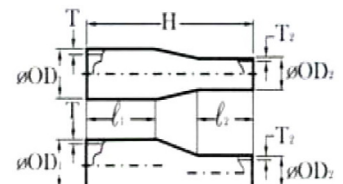

大小頭 Reducer

UNIT : mm

公稱尺寸 Normal Pipe Size	快接 Tee [J-TEE] Joint Tee			快接大小頭 [J-TEE] Joint Reducer		快接管帽 [J-CAP] Joint Cap		
								
	快接頭 Joint 1/4" ,3/8" ,1/2"			快接頭 Joint 1/4" ,3/8" ,1/2"		快接頭 Joint 1/4" ,3/8" ,1/2"		
OD(OD1)	C	P	M	H	H	E	Q	Q
INCH-SIZE								
1/4"	43	31.5						
3/8"	45	33.5		80	90			
1/2"	45	35		85	95			
5/8"	52	36.5		100	110			
3/4"	52	38		110	120	19.1	48	58
1"	55	42		115	152	25.4	55	65
A-SIZE								
8A	45	35	45	90	100			
10A	52	37	47	100	110	16.1	48	58
15A	52	39.5	49.5	110	120	25.4	55	65
20A	55	42.5	52.5	115	125	25.4	55	65
25A	59	46.5	56.5	130	140	38.1	68	78
32A	68	51	61			38.1	68	78
40A	68	54	64			38.1	68	78
50A	68	60	70			38.1	68	78
65A	72	68	78			38.1	68	78
80A	72	74.5	84.5			50.8	81	91
100A	72	87	97			63.5	94	104
125A	100	100	110			76.2	107	117
150A	110	113	123			88.9	120	130
200A	120	138.5	148.5			101.6	133	143

圖形Drawing

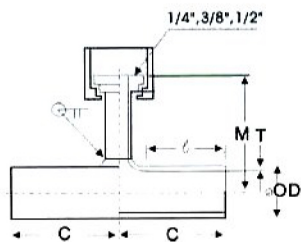

快接 Tee Joint Tee

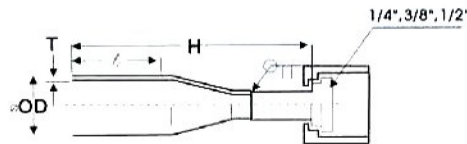

快接大小頭 Joint Reducer

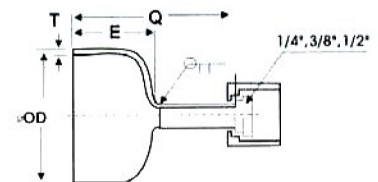

快接管帽 Joint Cap

UNIT : mm

公稱尺寸 Normal Pipe Size						
	管端長度 Length at	最小孔距 Pitch min				
OD(OD1)	EL	P	2	3	4	4
INCH-SIZE						
1/4"	50	85	185	270	355	440
3/8"						
1/2"						
5/8"						
3/4"						
1"						
A-SIZE						
8A	50	85	185	270	355	440
10A						
15A						
20A						
25A						
32A	60	95	215	310	405	500
40A	65	100	230	330	430	530
50A	70	110	250	360	470	580
65A	80	180	340	520	700	880
80A	100	190	390	580	770	960
100A	120	210	450	660	870	1080
125A	125	210	460	670	880	1090
150A	140	220	500	720	940	1160
200A	160	220	540	760	980	1200
圖形Drawing						
<p>支管高度尺寸 Branch tube size 1/4", 3/8", 1/2"</p> <p>一管多通 [MULTI-W]</p>			<p>支管高度尺寸 Branch tube size 1/4", 3/8", 1/2"</p> <p>一管多通 [MULTI-J]</p>			

UNIT : mm

公稱 尺寸 Normal Pipe Size	襯套 [JIS 10K][J5K] Stub End				法蘭片 [FLAGE][BLIND] JIS Flange,Blind									鐵弗龍墊圈 [FEFLON-P] Teflon Packong 厚度 THICKNESS t=2		
	長度 Length	直徑 Diameter of lap		弧度 Corner	長度 Length	JIS 10K				JIS 5K				JIS 10K		JIS 5K
		FF	JIS 10K			JIS 5K	R	FP	外徑 Outside din	厚度 Thickness	螺桿數 No of bolts	螺桿直徑 Din of	外徑 Outside din	厚度 Thickness	螺桿數 No of Bolts	
OD	FF	JIS 10K	JIS 5K	R	FP	D	FT	N	M	D	FT	N	M	OD	ID	OD
INCH-SIZE																
3/4"	55	51		3	100	95	12	4	M12					58	19.5	
1"	55	56		3	100	100	14	4	M12					63	26	
A-SIZE																
10A	55	46	39	3	100	90	12	4	M12	75	9	4	M10	53	18	45
15A	55	51	44	3	100	95	12	4	M12	80	9	4	M10	58	22	50
20A	55	56	49	3	100	100	14	4	M12	85	10	4	M10	63	28	55
25A	55	67	59	3	100	125	14	4	M16	95	10	4	M10	74	35	65
32A	70	76	70	3	100	135	16	4	M16	115	12	4	M12	84	43	78
40A	70	81	75	3	100	140	16	4	M16	120	12	4	M12	89	49	83
50A	70	96	85	4	100	155	16	4	M16	130	14	4	M12	104	61	93
65A	75	116	110	4	100	175	18	4	M16	155	14	4	M12	124	77	118
80A	75	126	121	5	100	185	18	4	M16	180	14	4	M16	134	90	129
100A	75	151	141	5	100	210	18	8	M16	200	16	8	M16	159	115	149
125A	85	182	176	5	200	250	20	8	M20	235	16	8	M16	190	141	184
150A	90	212	206	5	200	280	22	8	M20	265	18	8	M16	220	167	214
200A	90	262	252	5	200	330	22	12	M20	320	20	8	M20	270	218	260
圖形Drawing																
<p>襯套 Stub End</p> <p>$t \geq T$</p>										<p>管法蘭 Pipe Flange</p>						

雙套管配件 DOUBLE FITTING

UNIT : mm

公稱尺寸 Normal Pipe Size		直徑長度 Straight end		彎頭 Elbow [D-90][D-45]			同徑 Tee Equal Tee [D-ET]		一管多通 Multi-T
內管 Inter Tube	外管 Outer Tube	e1	e2	R	A	B	C1,C2	C1,C2	ALL Size are available upon requested
	1/2" x 1.24t	40	29	25	94	80	82	42	
	8A x S5S	40	29	26	95	80	82	42	
3/8"x1t	5/8" x 1t	40	36	28	104	88	89	49	
	5/8" x 1.24t	40	36	28	104	88	89	49	
	10A x S5S	40	36	30	106	89	89	49	
1/2" x 1t	3/4"x1.24t	40	36	35	111	91	92	52	
1/2" x 1.24t	15A x S5S	40	36	38	114	92	92	52	
3/4" x 1.24t	20A x S5S	40	36	47.6	124	96	105	65	
		40	36	47.6	124	96	105	65	
3/4" x 1.65t		40	36	47.6	124	96	105	65	
1" x 1.24t	25A x S5S	40	36	57.2	134	100	108	68	
1" x 1.65t		40	36	57.2	134	100	108	68	
1 1/2 x 1.65t	2" x 1.65t	46	46	95.3	188	132	123	77	
2" x 1.65t	2 1/2"x1.65t	46	51	120	217	147	136	90	
10A x S5S	20A x S5S	40	36	47.6	124	96	95	55	
15A x S5S	25A x S5S	40	36	57.2	134	100	99	59	
20A x S5S	32A x S5S	40	46	76.2	163	118	114	74	
25A x S5S	40A x S5S	40	46	95.3	182	126	117	77	
30A x S5S	50A x S5S	46	46	114.3	207	140	129	83	

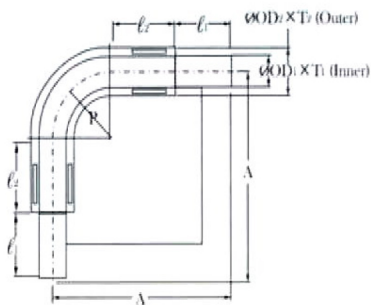

彎頭 Elbow 90°

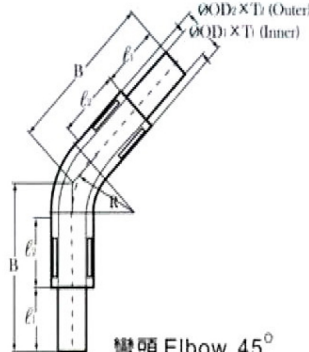

彎頭 Elbow 45°

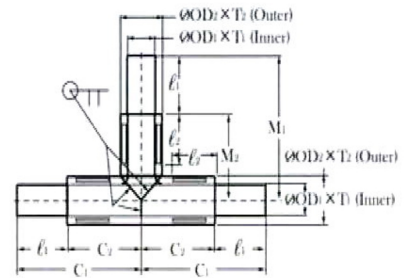

同徑 Equal Tee

UNIT : mm

大徑端 Large end	內管 Inter Tube		外管 Outer Tube	
	異徑端 Small end		大徑端 Large end	異徑端 Small end
1/4"	[1/8 "]		1/2"	3/8"1/4"
			8A	1/2"3/8"1/4"
3/8"	[1/4"]		5/8"	1/2",8A
			10A	1/2",8A
1/2"	3/8" ,[1/4"]		3/4"	5/8", 1/2", 10A(8A)
			15A	5/8", 1/2", 10A(8A)
3/4"	1/2" ,[3/8" ,1/4" ,10A]		20A	20A, 15A, 10A, 8A, 3/4", 1/2"
			1"	3/4", 5/8", 1/2", 15A(10A~8A)
1"	3/4" ,1/2" ,[3/8" ,1/4" ,15A](10A)		1 1/4"	1", (3/4", 20A), (5/8"~1/2", 15A~8A)
			25A	25A, 20A, 15A, 10A, 8A, 1", 3/4", 1/2"
1 1/2"	1" ,[3/4" ,25A](1/2" ~1/4" ,32A~10A)		2"	(1 1/4"), 1", (40A), (3/4"~1/2", 32A~8A)
2"	1 1/2" ,1" ,(3/4" ~1/4" ,32A~10A)		2 1/2"	2", 1 1/4", 50A(1"~1/2", 40A~8A)
10A	[1/2" ,3/8" ,1/4"]		20A	15A, 10A, 8A, 3/4", 1/2"
15A	[10A, 3/4" ,1/2" ,3/8" ,1/4"]		25A	20A, 15A, 10A, 8A, 1", 3/4", 1/2"
20A	15A[10A, 1" ,3/4" ,1/2" ,3/8" ,1/4"]		32A	25A, 20A, 15A, [1 1/4"], (10A, 8A, 1", 3/4", 1/2")
25A	20A, 15A, [10A, 1" ,3/4" ,1/2" ,3/8" ,1/4"]		40A	32A, 25A, 20A, 15A, (10A~8A, 1 1/4"~1/2")
32A	25A, 20A, 15A[1 1/2"](10A, 1" ~1/4")		50A	40A, 32A, 25A, 20A, [2"](15A~8A, 1 1/4"~1/2")

圖形 Drawing



雙套管同心大小頭 Double Reducer

內管 Inter Tube	外管 Outer Tube	內管 Inter Tube			內管 Outer Tube			外接頭 Joint Size
		C1	C2		C3	M		
			母 Female	公 Male		母 Female	公 Male	
1/4"	1/2"	85	80	90	45	35	45	1/4"
	8A	85	80	90	45	35	45	
3/8"	5/8"	92	87	97	52	36.5	46.5	1/4"
	10A	92	87	97	52	37	47	3/8"
1/2"	3/4"	92	87	97	52	38	48	1/4"~1/2"
	15A	92	87	97	52	39.5	49.5	
3/4"	1"	95	90	100	55	42	52	
	20A	95	90	100	55	42.5	52.5	
1"	1 1/4"	99	94	104	59	45.5	55.5	
	25A	99	94	104	59	46.5	56.5	
10A	20A	95	90	100	55	42.5	52.5	
15A	25A	99	94	100	59	46.5	56.5	

圖形 Drawing

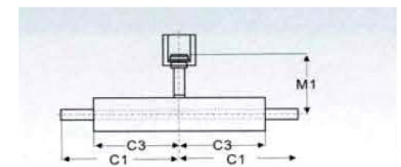

雙套管外接 Tee Double Joint Tee

UNIT : mm

公稱尺寸 Notmal Tube Size				內管 Inter Tube		外管 Outer Tube	
內管 Inter Tube		外管 Outer Tube		C1	M1	C2	M2
母管 Normal Tube Size	支管 Branch Tube Size	母管 Normal Tube Size	支管 Branch Tube Size				
3/8"	1/4"	5/8", 10A	8A, 1/2"	87	84	47	44
1/2"	1/4"	3/4", 15A	8A, 1/2"	87	84	47	44
	3/8"		10A, 5/8"	92	92	52	52
3/4"	1/4"	1", 20A	8A, 1/2"	87	87	47	47
	3/8", 1/2"		10A, 5/8", 15A, 3/4"	95	95	55	55
1"	1/4"	1 1/4", 25A	8A, 1/2"	87	90	47	50
	3/8", 1/2", 10A, 3/4", 15A		10A, 5/8", 15A, 3/4", 20A, 1", 25A	99	99	59	59
1 1/2"	1/4"	2"	8A, 1/2"	103	97	57	57
	3/8", 1/2", 10A, 3/4", 15A, 1"		10A, 5/8", 15A, 3/4", 20A, 1", 25A, 1 1/4"	114	105	68	65
	20A, 25A		32A, 40A	123	117	77	77
2"	1/4"	2 1/2"	8A, 1/2"	107	103	61	63
	3/8", 1/2", 10A, 3/4", 15A, 1"		10A, 5/8", 15A, 3/4", 20A, 1", 25A, 1 1/4"	118	111	72	71
	20A, 25A		32A, 40A, 2", 50A	136	123	90	83
	1 1/2", 32A		32A, 40A, 2", 50A	136	129	90	83
10A	1/4"	20A	8A, 1/2"	84	87	47	47
	3/8", 1/2"		10A, 5/8", 15A, 3/4"	95	95	55	55
15A	1/4"	25A	8A, 1/2"	87	90	47	50
	3/8", 1/2", 10A, 3/4"		10A, 5/8", 15A, 3/4", 20A, 1"	99	99	59	59
20A	1/4"	32A	8A, 1/2"	97	94	57	54
	3/8", 1/2", 10A, 3/4", 15A, 1"		10A, 5/8", 15A, 3/4", 20A, 1", 25A, 1 1/4"	108	102	68	62
25A	1/4"	40A	8A, 1/2"	97	97	57	57
	3/8", 1/2", 10A, 3/4", 15A, 1"		10A, 5/8", 15A, 3/4", 20A, 1", 25A, 1 1/4"	108	105	68	65
	20A		32A	117	117	77	77
32A	1/4"	50A	8A, 1/2"	103	103	57	63
	3/8", 1/2", 10A, 3/4", 15A, 1"		10A, 5/8", 15A, 3/4", 20A, 1", 25A, 1 1/4"	114	111	68	71
	20A, 25A		32A, 40A	129	123	83	83

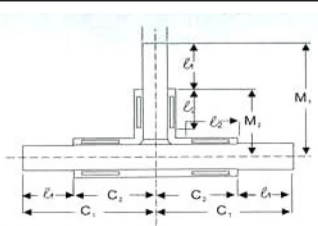
圖形 Drawing	內管 外管組合表	
 <p>雙套管異徑 Tee, Double Reducing Tee</p>	Inter Tube-Outer Tube combination table	
	內管 Inter Tube	外管 Outer Tube
	1/4" x1t	1/2" x1t
		1/2" x1.24t
	3/8" x1t	8" x1t
		5/8" x1t
		5/8" x1.24t
	3/4" x1.24t	10AxS5S
	3/4" x1.65t	20AxS5S
	1" x1.24t	1" x1.24t
	1" 1.65t	1" x1.65t
	1 1/2" x1.65t	25AxS5S
	2" x1.65t	1 1/4" x1.65t
	10 x S5S	2" x 1.65t
	15A x S5S	2 1/2" x1.65t
20A x S5S	20AxS5S	
25A x S5S	25AxS5S	
32A x S5S	32AxS5S	
	40AxS5S	
	50AxS5S	